

Specifications

| | |
|-----------------------|--|
| Input Level | MIC setting: -40 dBu typical LINE setting: +4 dBu typical |
| Gain | 40 dB |
| Output Level | +18 dBu max |
| Frequency Response | 20Hz to 20 KHz (-1 dB) |
| THD + N | Less than 0.03% @ 1 kHz, +4 dBu output |
| Signal-to-Noise Ratio | 90 dB @ -10dBu input |
| Phantom Power | Dual regulated 48 volt power supplies Current to 14 mA (direct short) |
| Battery Type | One 9 volt alkaline battery LED battery indicator |
| Battery Duration | 4 hours typical (no phantom) |
| Case | Powder coated aluminum |
| Dimensions | 6.25" L x 2.5" W x 1.25" H |
| Weight | 16 oz |

Limited One Year Warranty

This warranty covers any defects or malfunction in your new BeachTek adapter for one year.

BeachTek will replace any defective or malfunctioning adapter, within the warranty period, with a new unit at no charge. The warranty does not cover damage resulting from accident, alteration, misuse or abuse. The device must be sent to our service center at your expense.

Should you require service please contact us first before returning the unit to us. Return instructions can be found on our website at www.beachtek.com/questions.html

Upon receiving the returned adapter it will be inspected and replaced if found defective. The unit will be shipped back to you within five business days at our expense.

BeachTek Inc.
1855 Kirschner Road, Suite 230
Kelowna, BC, V1Y 4N7

tel (416) 690-9457
email adapter@beachtek.com
web www.beachtek.com

©2008 BeachTek Inc.

DXA-6HD

Operating Instructions for the DXA-6HD High Definition Adapter
- For use on the Sony FX1



The BeachTek DXA-6HD is a two channel, XLR adapter with built-in low noise preamplifiers and 48 volt phantom power supplies. This adapter is designed to easily attach two professional, balanced microphones or wireless systems to the Sony FX1 camcorder.

The DXA-6HD is very easy to set up and use. Its rugged construction ensures years of use and its compact size fits neatly under the camcorder - can also be mounted to any standard tripod. The DXA-6HD provides exceptionally quite preamplifiers to provide clean, powerful audio from virtually any microphone to ensure the best possible sound recording.

- Before using this high quality device, please read this operating manual thoroughly to obtain the highest performance.
- Please contact us if you have any problems or questions.

BeachTek

Front Panel Controls and Indicators

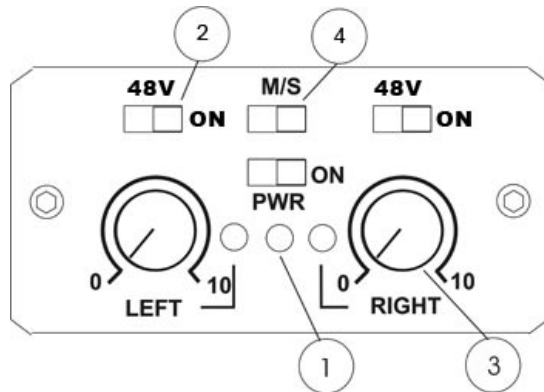

Mounting and Connection

Mount the DXA-6HD securely to the tripod bushing on the under side of your camcorder. Connect the cable from the DXA-6HD to the camcorder's microphone jack. The onboard microphone should now be disabled.

Camera Setup

Set the audio mode switch on the back of the camcorder to MAN to deactivate the AGC. Turn the AUDIO LEVEL thumbwheel on the camcorder to 3 on the dial. Set the input level on the camera menu to EXT LINE. This bypasses the camcorder's preamplifiers for superior audio. You are now ready to attach external microphones to the adapter.

Adapter Controls and Connectors

1. Power

Install a fresh 9 volt alkaline battery in the adapter if you wish to use phantom power. Turn on the unit to activate the phantom power supplies. The Power LED should light to indicate good battery power. Turn off the power when not in use to conserve battery power.

2. Phantom Power

If your condenser microphone requires 48 volts phantom power to operate, first connect the microphone to the adapter. Activate the PWR ON switch and then the PH ON switch for the channel it is connected to. The LED above the corresponding channel trim control should light to indicate that 48 volt power is present. Do not plug dynamic microphones, unbalanced devices, wireless receivers or feeds from mixing boards into the adapter with the phantom power activated as it may damage the connecting device.

3. Trim Controls

Each channel of the DXA-6HD has a trim control to adjust the input signal level.

Adjust the trim controls on each channel of the adapter for the desired volume level on camcorder. Use the level indicator on the camera as a guide. Be sure not to activate the red bar on the level meter to avoid distortion.

As a guide, the recording levels should be no higher than -12 dBFS (Full Scale). Please refer to your camcorder's user manual for more information on setting the proper recording levels.

Rear Panel Controls and Connections

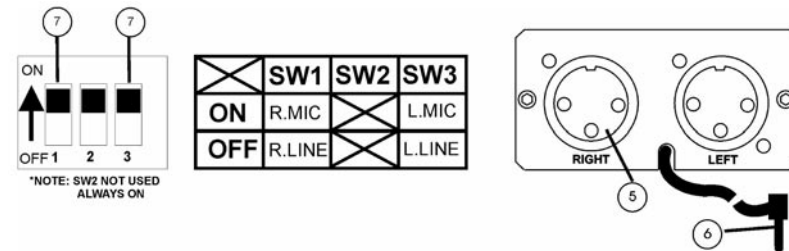

4. MONO / STEREO Switch

The MONO setting mixes both channels together and sends the audio to both the right and left channels which is ideal when only one microphone is being used. Stereo keeps both channels separated when two microphones are connected to the adapter for two discrete audio channels. When in MONO mode, be sure to keep the trim control on the unused channel fully clockwise to reduce the loading effect on the working channel.

5. XLR Inputs

The two XLR inputs can accept balanced or unbalanced connections. To convert the input to unbalanced, simply ground pin 1 to 3 on the XLR input cable. Be sure to turn off the phantom power for any channel that has an unbalanced device connected to it.

6. Output Cable

The attached shielded cable terminates in a gold plated, stereo mini plug connector. Plug this into the microphone jack on your camcorder.

Bottom Dip Switches

7. MIC / LINE Switches

To connect a microphone to either channel of the DXA-6HD, set the corresponding MIC/LINE switch to MIC. To connect a line level output from a mixer to the DXA-6HD, set the MIC/LINE switch to LINE to activate a 40 dB pad. This attenuates the signal to the proper level so that it will not overdrive the input of your camcorder.

Please call us if you have any questions.